

1010210304 กายทิมเบิล สำหรับสายยึดโยง 50 - 95 ตร.มม.

ต้นฉบับ

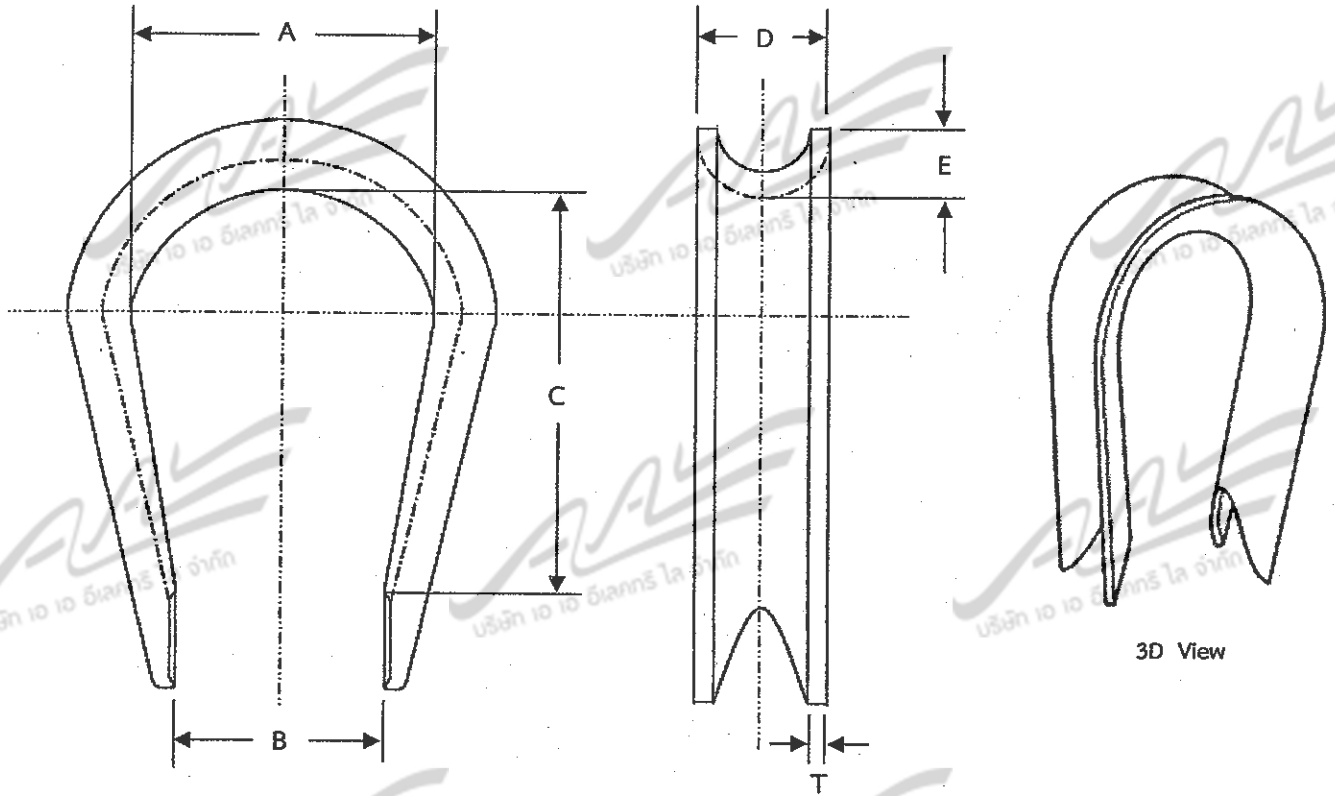

No.	PEA Mat. No.	Dimension in mm						Used For Steel Wire Section and Diameter
		A	B	C	D	E	T	
1	1010210304	32	20	51	17.5	11	1.75	Steel Wire 50-95 mm ² Diameter 9 - 12.5 mm (3/8" - 1/2")

Note : Zinc Coating Thickness (Hot Dip Galvanized) According to PEA Standard
[425 - 500 g/m² (60 - 70 microns)]

สำเนา

Approximate , Tolerance ±5%

Draft by 		A A ELECTRI LI CO., LTD 95 Moo 5 Lumpo Bangbuatong Nonthaburi Thailand , 11110 02 - 158 - 4576 - 7 www.aal2008.com		Thimble , Guy , For Steel wire 50 - 95 mm ²		PEA Material No. 1010210304	
Approve 		กายทิมเบิลสำหรับสายยึดโยง 50 - 95 ตร.มม.		Rev.0 Feb 01 2016		PEA Specification No. R-88/2546	
				Scale NTS		PEA Drawing No. K31 - 09048	
				Dimension mm		Sheet 1/1	
				Material Steel			
				Revision		Drawing No. 1010210304-01-S-00-01	