

1020310000 คอนเนคเตอร์เข้าปลายสายอลูมิเนียม 25-35 ตร.มม.

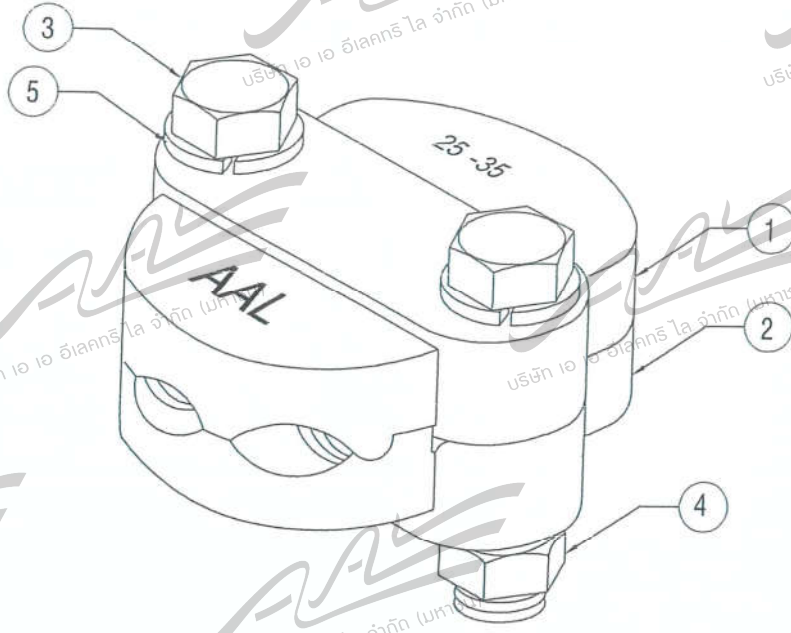

## ต้นฉบับ

Assembled with conductor	Al insulated compact cable 25-35 mm <sup>2</sup> (Dia. 6.42-7.56 mm)
Tightening torque	2.0 kg-m (137.6 lb-in)
Slipping strength, kgf	90% Al insulated compact cable 25 mm <sup>2</sup> = 379

ITEM	PART NAME	QTY.	DIMENSIONS	MATERIAL
1	UPPER BODY	1	FOR CABLE SIZE 25-35 sq.mm.	AL-ALLOY
2	LOWER BODY	1	FOR CABLE SIZE 25-35 sq.mm.	AL-ALLOY
3	HEX. HEAD BOLTS	2	M 8 X40 mm.	GALVANIZED STEEL
4	HEX. NUTS	2	M8	GALVANIZED STEEL
5	SPRING WASHERS	2	M8	GALVANIZED STEEL

สำเนา

Note : Zinc coating of Bolt M8 > 43 μm

Tolerance ±5%

A A ELECTRIC PUBLIC CO.,LTD. 95 Moo5, Lumpo, Bangbuatong Nonthaburi, Thailand, 11110 02 159 4576 - 7 www.aal2008.com	Title.	Dimension			
	Projcet.	1020310000 คอนเนคเตอร์เข้าปลายสายอลูมิเนียม 25-35 ตร.มม.			
	Material No.	-	Spec.No.	R-506/2546	
	Rev.0	Feb,13,2015	Scale	NTS	Dimension
				mm.	1 / 1
		Material See on drawing			
		DWG No.			
	Revision	1020310000-S-01-01			